

## SZN1204-IR License Plate Recognition Flash Lamp



### Product Overview

SZN1204-IR is designed as the high efficacy Xenon flash lamp for traffic enforcement system. Through camera control, it provides accurate synchronous flash light for snapshot. Under the condition of complete darkness, it helps camera system obtaining clearly pictures of number plate, vehicle body and cab. It's an ideal flash lamp for traffic enforcement system.

### Feature

- Low recycling time, applied for high speed snapshot
- Peak power flashing, effectively enhance quality of pictures
- Trigger by electric level or switching value
- Easily installation and adjustment
- Anti-glare design, effectively reduce the eye stimulation

### Technical Specification

Item	Specification
Working voltage	AC220V±10%/48Hz~52Hz
Flash energy	200J
Power consumption	average power < 100W(@1 flash/s), Maximum power In instant < 300W
Peak flash duration	1/30ms
Recycle time	< 67ms
Effective distance	16m~25m
Cover area	1 lane
Application	Toll free station and over speed snapshot
Pulse and comprehensive protection	False trigger protection
Trigger mode	electric level, +5VDC, switching value
Wavelength	infrared light
Operate life	≥20million times
Working temperature	-20~+70°C ( -40°C is available/light decay)
Working humidity	5%~90%@40°C, No condensation
Protection level	IP65
Net Weight	3.2kg
Dimension	385mm*175mm*200mm

## Intelligent Traffic Flash Lamp

### Picture & Dimension

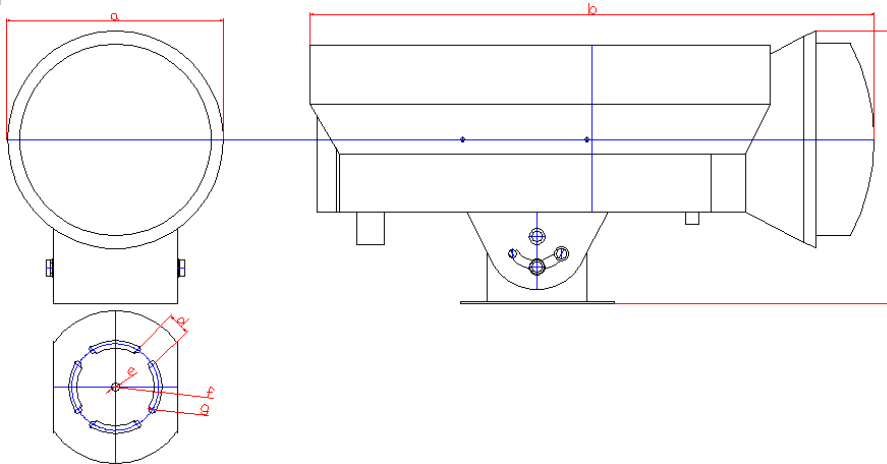

a: 175mm	b: 385mm
c: 220mm	d: 17.5mm
e: 7mm	f: 35mm
g: 3.5mm	

### Wiring Definition

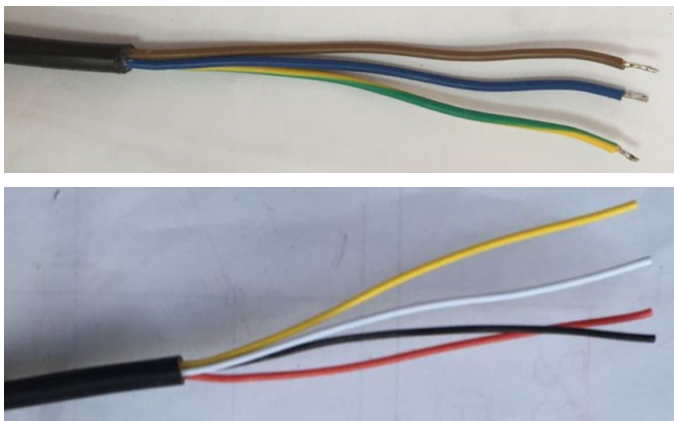

Base pin	Color of outgoing wire	Signal
1	Brown	Input AC220V L-line
2	Blue	Input AC220V N-line
3	Yellow-Green	Input AC220V PE
4	Red	Flash trigger + (electric level)*
5	Black	Flash trigger - (electric level)*
6	Yellow	Flash trigger + (switching value)*
7	White	Flash trigger - (switching value)*

\*Warning: Two pairs of flash trigger wire **electric level** and **switching value** cannot be connected at the same time. Please cut off one pairs before connects to another pairs.

### Matters need attention

1. It is forbidden to install this product upside down.
2. Except artificial reason and the force majeure, the light tube is under 20million times warranty, control circuit has 24months warranty, lifetime maintenance with cost price.
3. This lamp is expendable, light decay is normal phenomenon after long time use.
4. Using outdoor electronic product safety reasons, the ground wire must be connected to the qualified ground device to protect the products.
5. The product powered with high voltage. It is strictly prohibited to open personally.
6. To avoid water in, the power port must be downward and the power wire must not be tighten.
7. We seek to make the accuracy between product and data, but we can't cover all the application field. Specification and design are subjected to change without notice.