

S-SZN3103-IR LED Strobe Light

Version: V3

Product Overview

S-SZN3103-IR Digital LED Strobe Light is a high power and smart performance digital pulse strobe lamp applying for Intelligent Traffic System applications. It's suitable for traffic crossing; urban road and high way for number plate recognition and speed measurement. Complied with latest professional strobe control circuit, it can accurately control strobe flash time, brightness and output of high instantaneous power. It has rapid recycling time and long lifespan, through synchronization with the strobe lamp, ITS cameras can obtain clear pictures of number plate, vehicle body and cab under any kind of environment without influence of human eye.

Copyright Announcement

Trademark, name of software and hardware mentioned in this user manual are all belong to the corresponding company. Without our company's official permission, no organization or individual are allowed to copy or spread this user manual in any form by any means.

The contents of this manual will be changed without prior notice.



LPR/ANPR PICTURE



Intelligent Traffic Strobe Light**Specification**

Main Processor	High performance MCU
LED Type	16pcs high power IR LED
Wavelength	850nm
Beam Angle	10°(standard), 30°, 45° (optional)
On/Off Switch	Environmental brightness detection, switch on under low illumination
Strobe Interface (Default setting: Mode D)	Mode D: Strobe frequency is 100Hz , duty cycle is adjustable and continuous working
	Mode H: Strobe frequency is in accordance with doubling pulse of camera, duty cycle is adjustable and continuous working (Duty cycle of Hikvision camera should be <50%)
Power Supply	AC165~220V
LED Power	Average≤20W, Peak:40W
Effective Distance	10-25m, width 5-10m
Synchronization port	Strobe trigger input
Trigger Method	Low electrical level / Switching value
Housing Material	Aluminum+toughened glass
Cooling	Heating dissipating housing
Lightning Protection	Common mode 4KV, Different mode 2KV
Protection Level	IP67
Working Temperature	-40~+60°C
Storage Temperature	-40~+85°C
Net Weight	2.4kg
Dimension	122*125*134mm

Hardware**Strobe trigger port and power wire****Wiring Definition**

Strobe Trigger:

Base pin	Color of outgoing wire	Signal	Remark
1	Red	Trigger+	
2	Black	Trigger-	

Intelligent Traffic Strobe Light

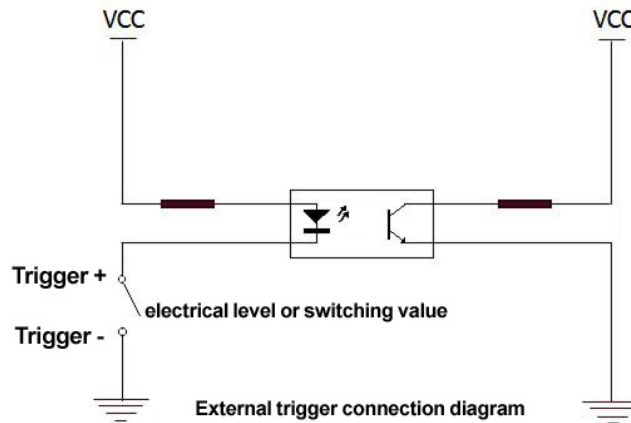

The principle diagram of interface

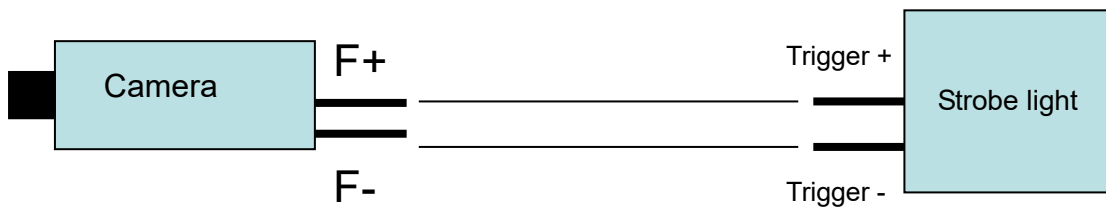

Connection between camera and strobe light

Warning

The power wire should connect to ground wire, otherwise may cause electrical shock.

Dimension

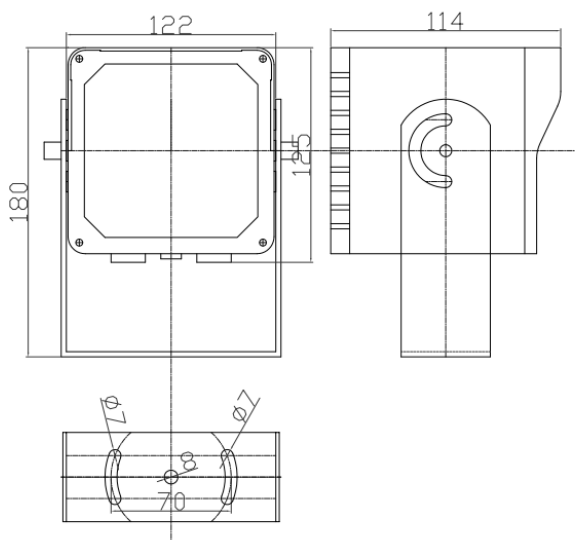

Certificate



After Sales Service

Product damaged except artificial reason and the force majeure is under 36 months warranty, lifetime maintenance with cost price.